

# ARC command.

1961 GstarCAD MY /KW April 15, 2022 [CAD Commands](#) 0 5496

The **ARC** command is used to create arcs.

## Command Access:

**Ribbon** : Home > Draw> Arc

**Menu** : Draw > Arc

**Command** : ARC

## Command Prompts:

Specify start point of arc or [Center]:

## Function Description:

Users could create arcs by specifying combinations of center point, endpoint, start point, radius, angle, chord length, and direction.

## Relative Glossary:

### Start point:

Specify the start point of arc.

**Note** : if pressing ENTER without specifying the start point, the last endpoint of straight line or arc will become start point and prompt to specify endpoint of arc. It will create an arc that tangent to the last straight line or arc or polyline.

**Second point**: Create an arc by three specified points; those points are all on the same circle. The first point is start point, the third point is endpoint, and the second point is one point on circle.

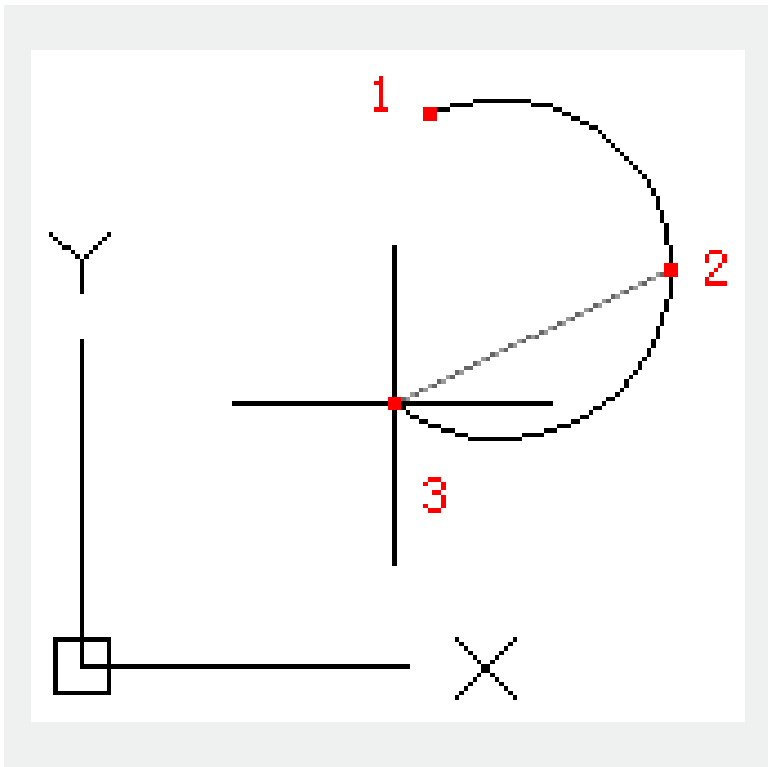

Those three points could specify an arc clockwise or anticlockwise.

Center:

Specify the center of a circle; the created arc is a part of circle.

**Endpoint:**

Specify the center 1 and create an arc from the start point 2 to the end point 3 in anticlockwise. The end point is on an assumed ray that started from the center point to the end point, so the endpoint may be not on created arc.

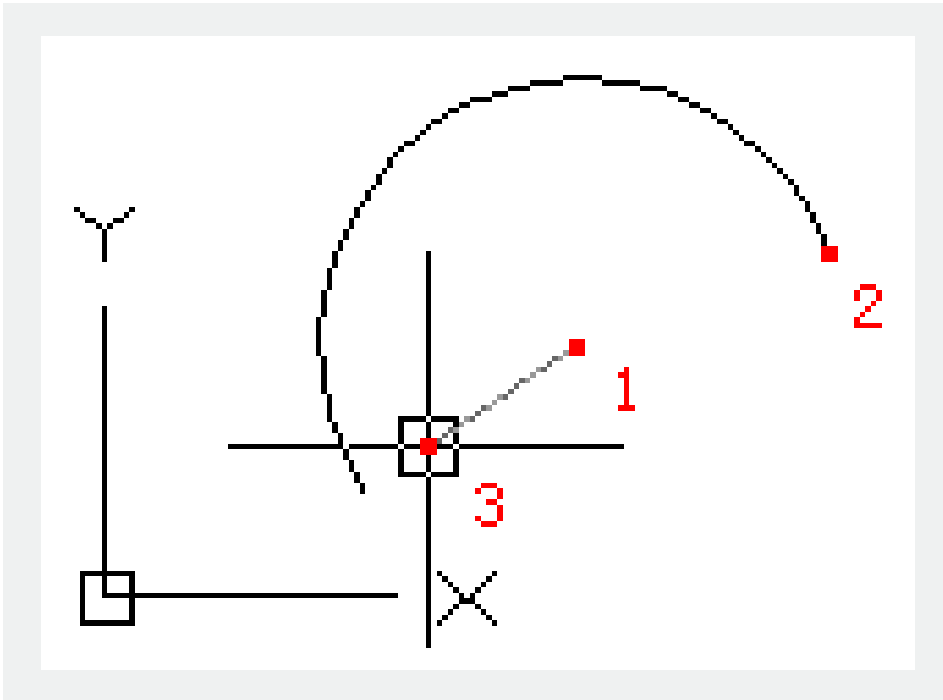

**Angle:**

Specify the center 1 and create an arc from the start point 2 with a specified included angle. If the included angle is negative, the arc will be created in clockwise; if it is positive, the arc will be created in anticlockwise.

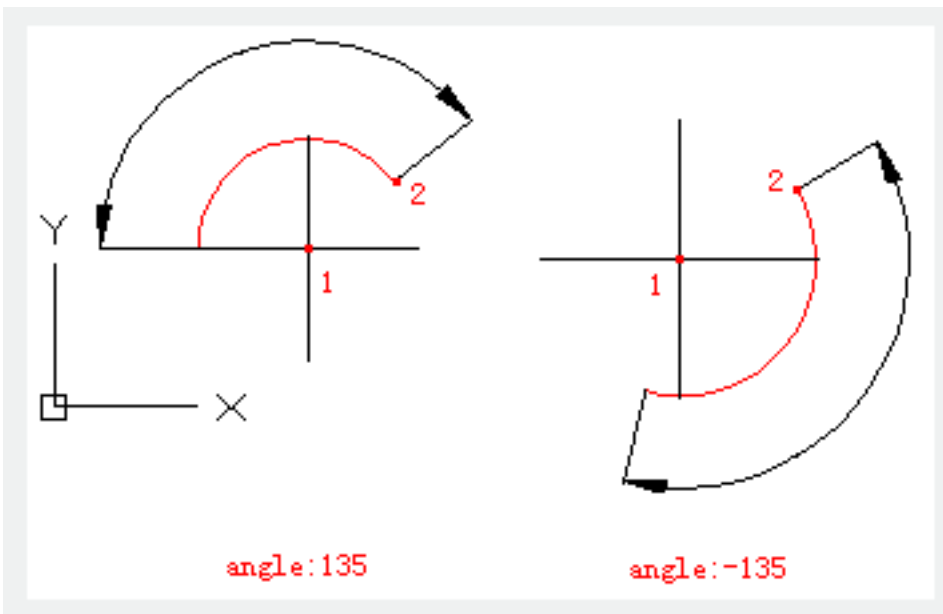

**Chord length:**

Create an arc by a specified chord length; the chord is a line segment from the start point to endpoint of arc. If specifying the chord length to a positive value, it will create a minor arc from the start point in anticlockwise direction; if specifying a negative value, it will create a major arc in anticlockwise direction

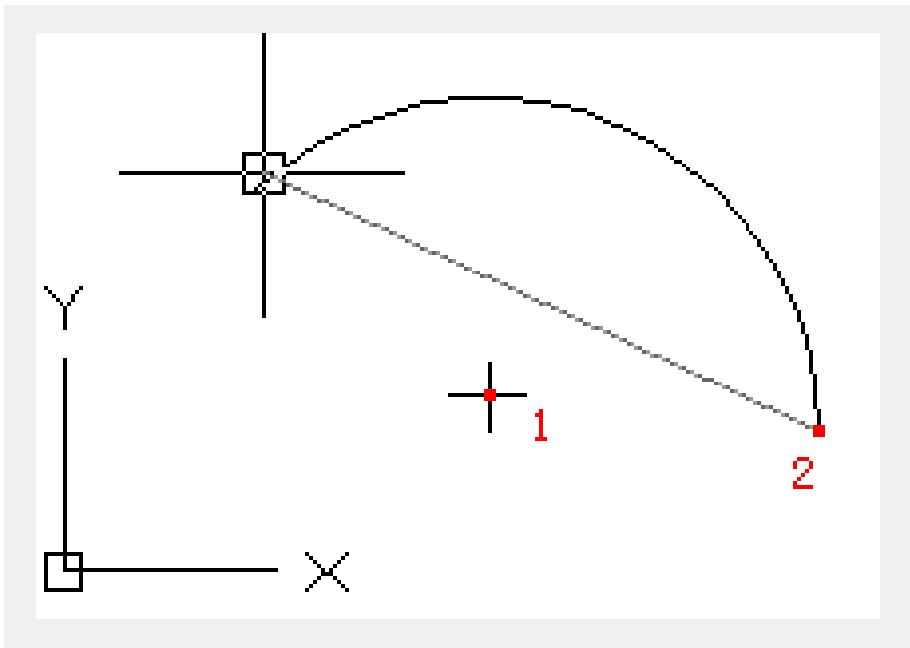

**End:**

Specify the endpoint of an arc.

**Center:**

Create an arc from start point to endpoint in anticlockwise direction. The end point is on an assumed ray that started from center point to the second specified point.

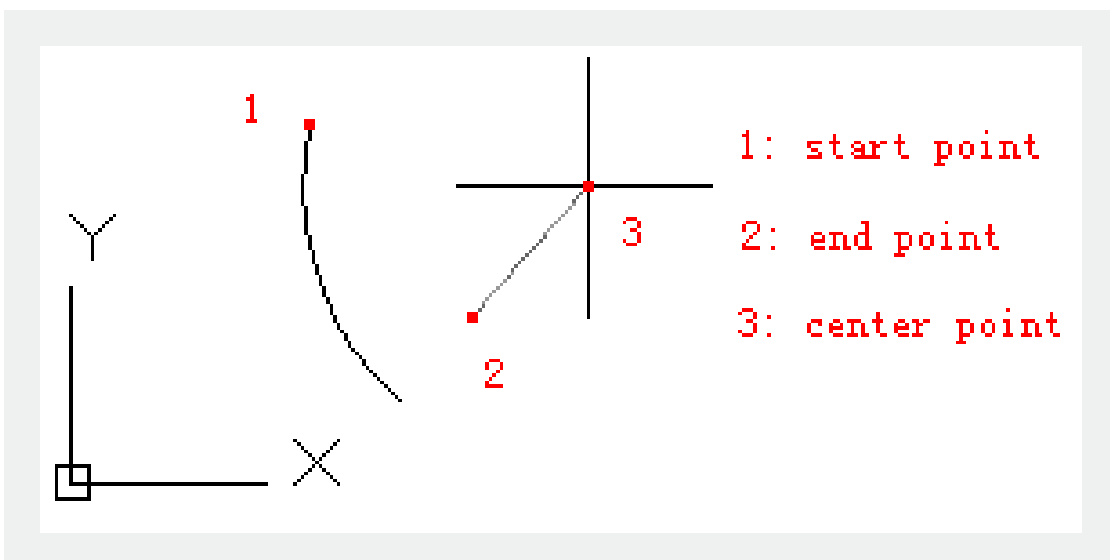

**Angle:**

Create an arc with a specified angle from start point to endpoint. If the inputted angle is negative, the arc will be created in clockwise direction.

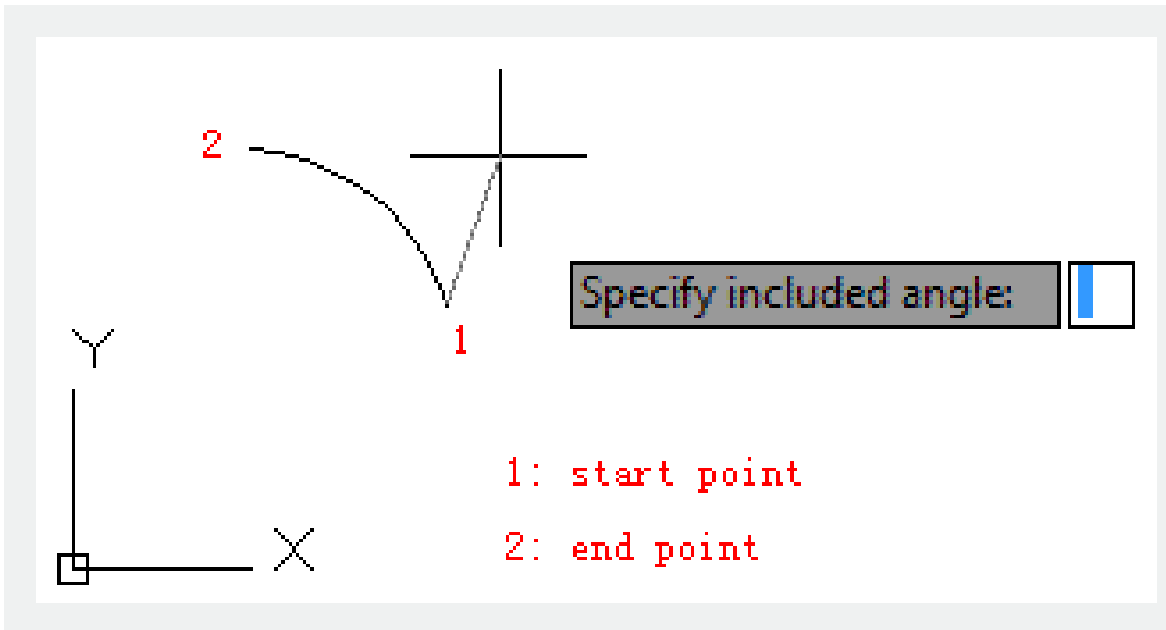

**Direction:**

Create an arc from start point to endpoint and specify the tangent line direction of the start point. Users only need to determine tangency direction without regard to anticlockwise or clockwise, major arc or minor arc.

**Center:**

Specify the center of an arc.

**Endpoint:**

The point 1 is center of arc. The arc is from the point 2 to point 3. It is created in anticlockwise. The point 3 is located on the assumed line from center point 1 to point 3.

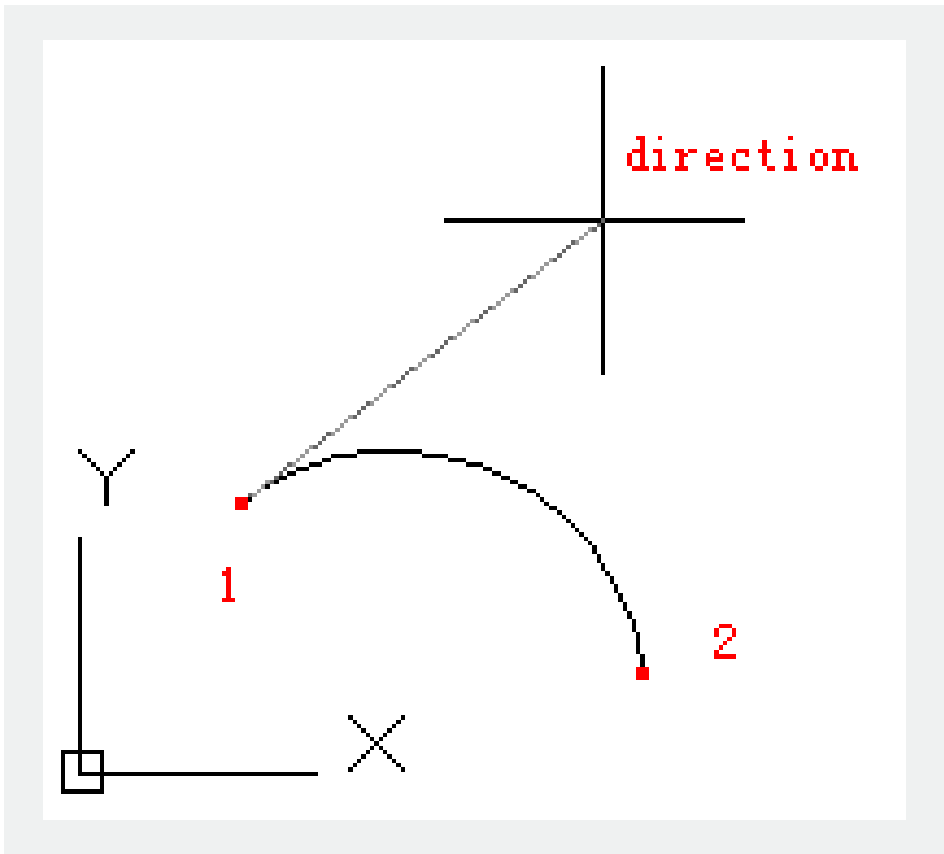

**Radius:**

Create a minor arc from the start point to end point. If inputting a negative value for radius, it will create a major

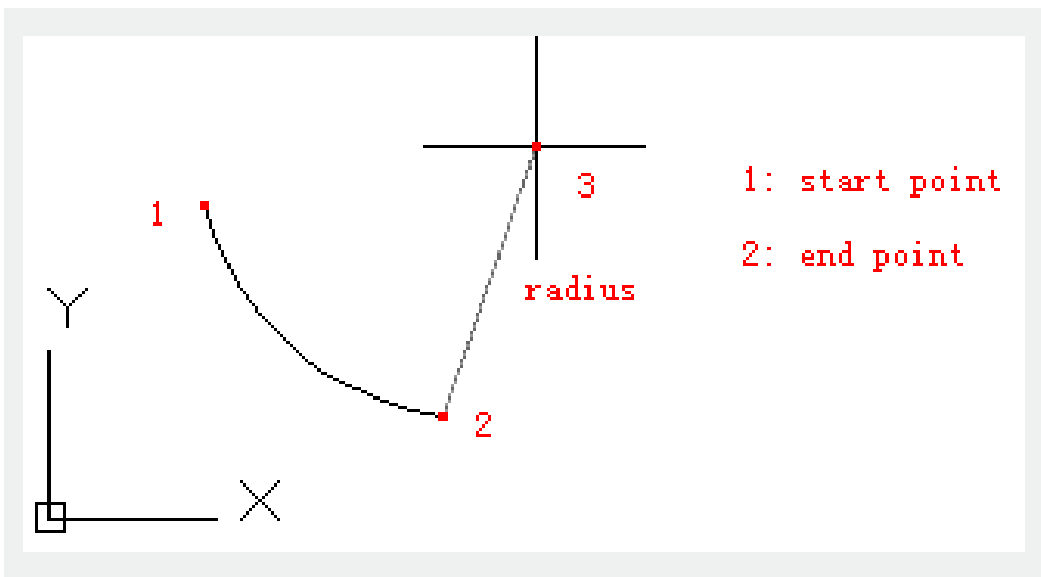

**Center:**

Specify the center of an arc.

**Endpoint:**

The point 1 is center of arc. The arc is from the point 2 to point 3. It is created in anticlockwise. The

point 3 is located on the assumed line from center point 1 to point 3.

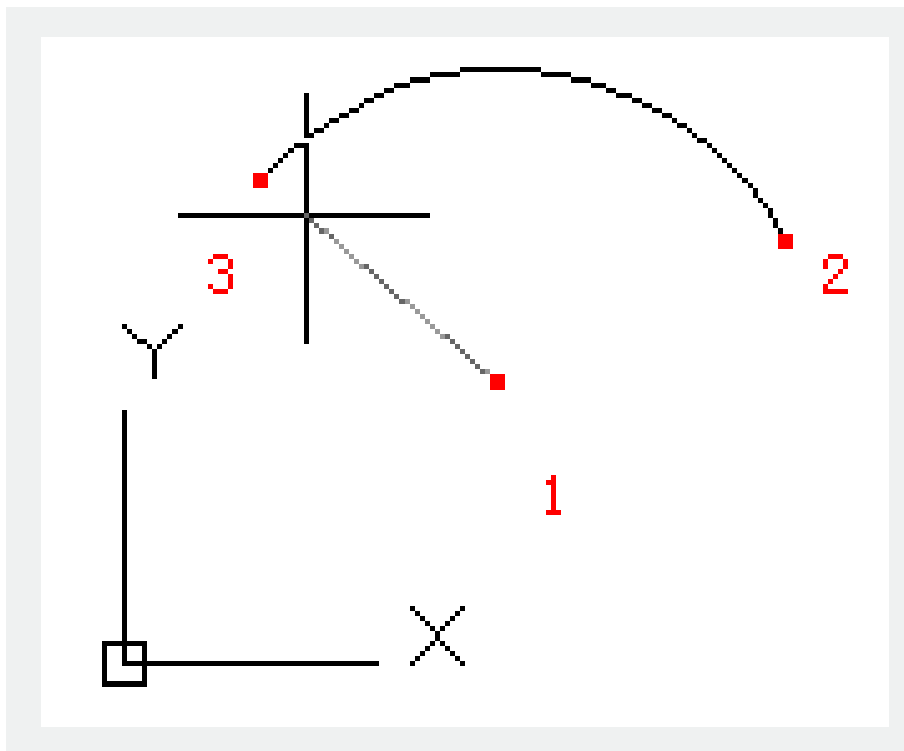

**Angle:**

The point 1 is center of arc. The included angle is from the point 2. It is created in anticlockwise. If inputting a negative angle, the arc will be created in clockwise direction.

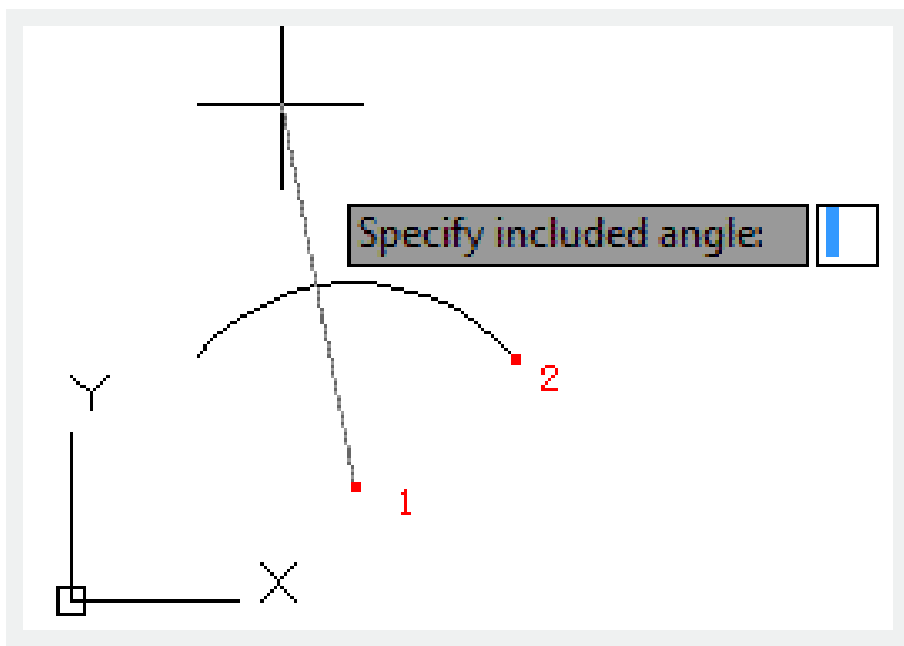

**Chord length:**

The point 1 is center of arc. The chord length is the distance from the point 2 to the endpoint. Users could create a major arc or minor arc by specified chord length. If inputting a positive chord length value, it will create a minor arc in anticlockwise; if inputting a negative chord length value, it will create a

major arc in anticlockwise.

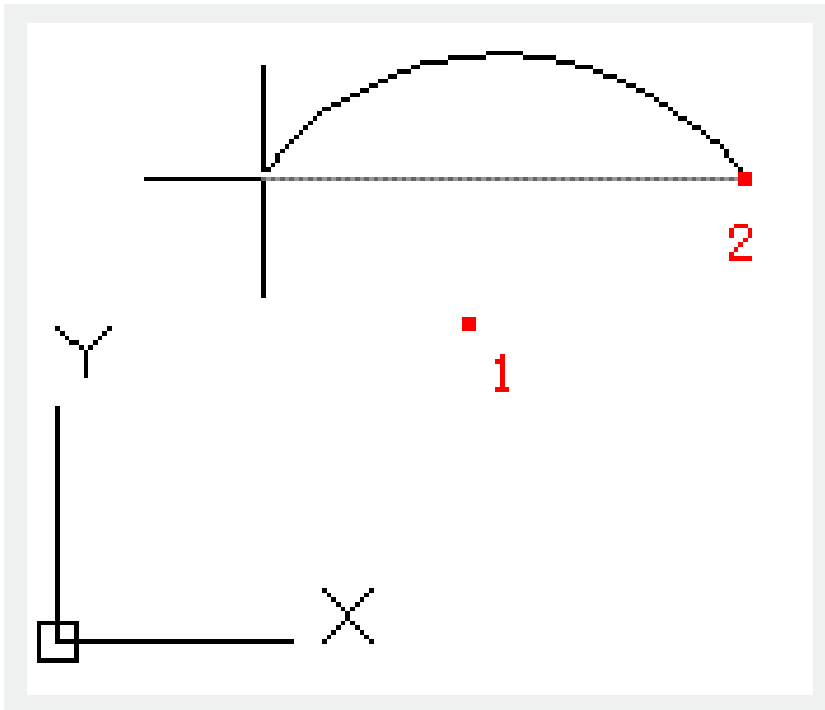

---

Related tutorial video:

- [Status bar related setting](#) 00:23
- [Line command](#) 00:33
- [Polar](#) 00:39
- [Edit objects + grips](#) 00:56
- [Grips System variable](#) 00:56
- [Use grips to edit objects](#) 00:56
- [Properties command](#) 01:16
- [Display and change the properties of objects](#) 01:16
- [Linetype command](#) 01:26
- [-Linetype command](#) 01:26
- [Control Line Scale](#) 01:26
- [Color command](#) 01:33
- [Change the color of an object](#) 01:33

- [Set the current color](#) 01:33
  - [Polyline command](#) 02:00
  - [Fillet command](#) 02:40
  - [Draw Rectangles and Polygons](#) 03:01
  - [Revcloud command](#) 03:10
  - [Donut command](#) 03:14
  - [Draw Donuts](#) 03:14
  - [Edit objects + grips](#) 03:23
  - [Grips System variable](#) 03:23
  - [Use grips to edit objects](#) 03:23
  - [ARC command](#) 03:54
  - [How to draw an arc with specific arc length](#) 03:54
  - [Circle command](#) 04:42
  - [Concentric circle command](#) 04:54
  - [Properties command](#) 05:54
  - [Mirror command](#) 05:16
- 

- [Status bar related setting](#) 00:15
- [Draw Rectangles and Polygons](#) 00:26
- [Rectang command](#) 00:26
- [Polygon command](#) 00:26
- [Arc command](#) 00:30
- [Trim command](#) 00:40
- [Extend command](#) 01:51
- [Offset command](#) 02:23
- [Stretch command](#) 03:35
- [Edit objects + grips](#) 03:55
- [Break object](#) 04:13
- [Circle command](#) 05:51
- [Draw circles](#) 05:51
- [Break command](#) 05:56
- [Join command](#) 06:32
- [Scale command](#) 06:53
- [Lengthen command](#) 07:29
- [Copy command](#) 08:20
- [Rotate command](#) 08:47
- [Move command](#) 09:07

Above video sources from [TUTORIAL - GETTING STARTED WITH GSTARCAD](#), enrol now for

free.

---

- [View command](#) 00:25
- [Menus and Shortcut Menus](#) 00:37
- [Unisolateobjects command](#) 00:37
- [Qnew command](#) 00:48
- [Status bar related setting](#) 00:52
- [Box command](#) 01:03
- [Union command](#) 01:50
- [Xedges command](#) 02:03
- [Filletedge command](#) 02:08
- [Vscurrent command](#) 02:45
- [Extrude command](#) 03:27
- [Rectang command](#) 04:22
- [Move command](#) 04:45
- [Line command](#) 05:06
- [ARC command](#) 05:16
- [Trim command](#) 05:23
- [Join command](#) 05:46
- [Convto surface command](#) 06:35
- [Slice command](#) 06:51
- [Solidedit](#) 08:32

Above video sources from [TUTORIAL - GETTING STARTED WITH GSTARCAD](#), enrol now for free.

Online URL: <https://www.kb2.gstarcad.com.my/article.php?id=1961>